



## SPECIFICHE TECNICHE

<b>MODELLO</b>	NIEF SIBILLA X	<b>CERTIFICAZIONE</b>	EPAC UNI EN15194
<b>TELAIO</b>	Alluminio 6061	<b>COLORE</b>	Grigio Carbon PT447C

## MOTORE E BATTERIA

<b>MOTORE</b>	NIEF XF 36V 250W	<b>COPPIA</b>	45 Nm
<b>BATTERIA</b>	Samsung 36V 18.2A 655Wh	<b>VELOCITA MAX ASSISTENZA</b>	25 Km/h
<b>DISPLAY</b>	KD LCD Bianco-Nero	<b>SOFT-START</b>	0-6 Km/h
<b>SENSORE PEDALATA</b>	1-5 Livelli di assistenza	<b>SENSORE PEDALATA ASSISTITA</b>	12 magneti

## MECCANICA

<b>PNEUMATICI</b>	Kenda 26x2.125	<b>PRESSIONE</b>	3.5 Bar / 50 PSI
<b>FORCELLA</b>	RST Ammortizzata	<b>PARAFANGO</b>	Plastica polipropilene
<b>FRENI</b>	Tektro E350 Idraulico	<b>DISCO</b>	Tektro 160x24mm
<b>CAMBIO</b>	Shimano SIS 7 velocità	<b>RUOTA LIBERA</b>	Shimano 14-28T
<b>CATENA</b>	KMC	<b>PORTAPACCHI</b>	Portata max 25 kg

## DIMENSIONI E PESO

**DIMENSIONI** 1900x1200x704 mm

**PORTAPACCHI ANTERIORE** Portata max 12 Kg

**PESO** 26 Kg

**PORTATA MASSIMA** 130 Kg

**STATURA CICLISTA CONSIGLIATA**

da 160 a 185 cm

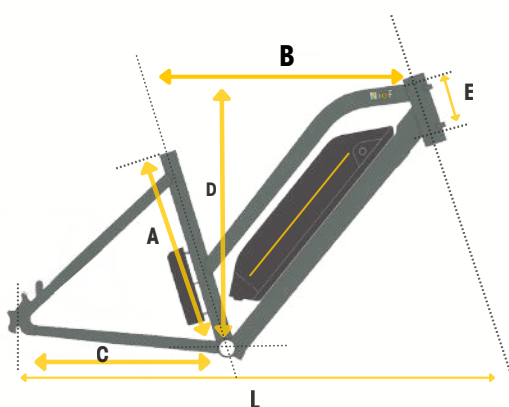

<b>A</b>	--- mm	<b>B</b>	570 mm
<b>C</b>	480 mm	<b>D</b>	--- mm
<b>E</b>	150 mm	<b>L</b>	1120 mm

## AUTONOMIA EBIKE

Percorso mediamente pianeggiante senza nessuno sforzo muscolare (pedalata simbolica)

Percorso con salite / pendenze 10-15% senza nessuno sforzo muscolare (pedalata simbolica)

Percorso mediamente pianeggiante con sforzo muscolare alto (130W)

PESO CONDUCENTE	85 Km	59 Km	106 Km
<b>60 KG</b>	85 Km	59 Km	106 Km
<b>70 KG</b>	76 Km	54 Km	95 Km
<b>80 KG</b>	69 Km	49 Km	87 Km
<b>90 KG</b>	64 Km	45 Km	80 Km
<b>100 KG</b>	59 Km	41 Km	73 Km
<b>110 KG</b>	55 Km	38 Km	68 Km

## NOTE

---



---



---



---

**SIBILLA X**  
**250W 36V 655Wh**
